

INSTALLATION MANUAL

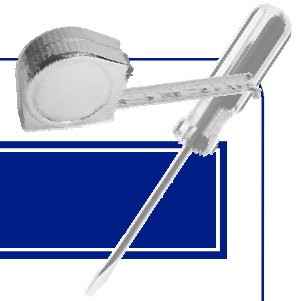

Table of Contents

Step	Installation	Contractor	Page
1	Install I/O Processor	Electrical	4
2	Install Electronic Motor Starter	Electrical	6
3	Install Keypad	Mechanical	8
4	Install Exhaust Temperature Sensor	Mechanical	9
5	Install Optic Sensors	Mechanical	13
6	Install Air Purge Unit	Mechanical	17
7	Install Cables	Mechanical	18
8	Install Options (if applicable)	Mechanical	23

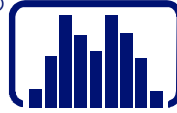

Tools & Materials Required

Tools Required

- Drill and Drill Bits (Cobalt is best for stainless steel) - bit sizes: 1/8" & 1/4"
- Hole Cutter or Punch for Stainless Steel with cutter sizes: 1-1/2" & 1-1/4"
- Adjustable Pliers and Adjustable Wrench
- Screwdrivers - Straight & Phillips, Large and Small
- Wire Cutter and Wire Stripper
- Measuring Tape and Level
- Step Ladder

Materials Required

- Suitable fasteners for mounting the I/O Processor and Electronic Motor Starter:
 - hollow cinder block (3/16" toggle bolts)
 - concrete or filled cinder block (lead anchors 1/2" dia. with 1/4" x 1-14" lag screws)
 - drywall (3/16" toggle bolts)
 - plywood (#8 X 1-1/4" wood screws)
 - metal back-plate (#8 X 1-1/4" sheet metal screws)
- Conduit and wire for wiring the I/O Processor and Electronic Motor Starters

Note: All high voltage wiring to be completed by trained service personnel. (Local code may require a licensed electrician.)

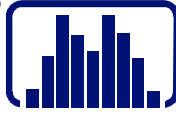

STEP

1

Install I/O Processor

A

Select I/O Processor Location

For new construction, the hood manufacturer typically provides a utility cabinet in which to mount the I/O Processor. If the hood has a utility cabinet with extra space, mount the I/O Processor (and Electronic Motor Starters) there.

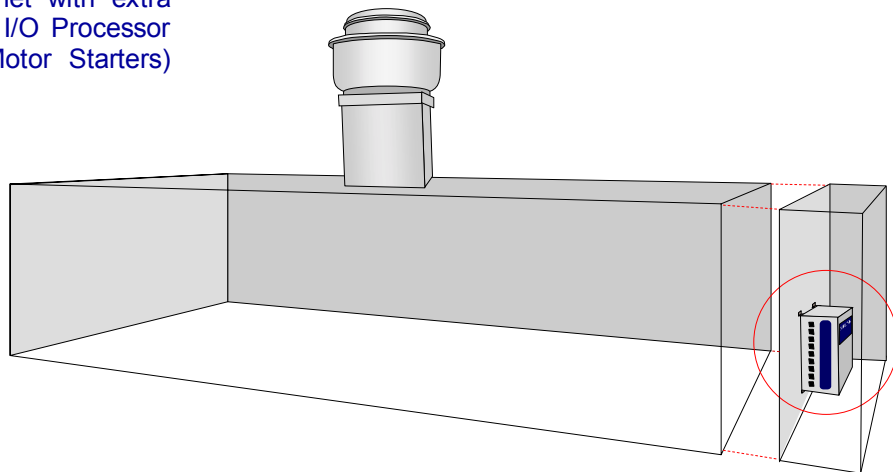

For retrofits, the I/O Processor is typically mounted above the hood. Select a location that is easily accessible and close to where the Keypad will be mounted. Ideally, you should secure it to a wall. DO NOT PENETRATE THE HOOD EXHAUST PLENUM.

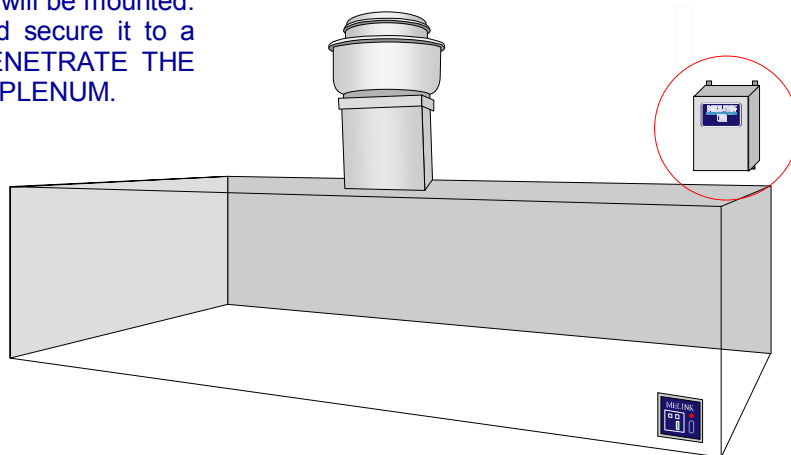



STEP

1

Install I/O Processor

B

Turn Off Power Switch

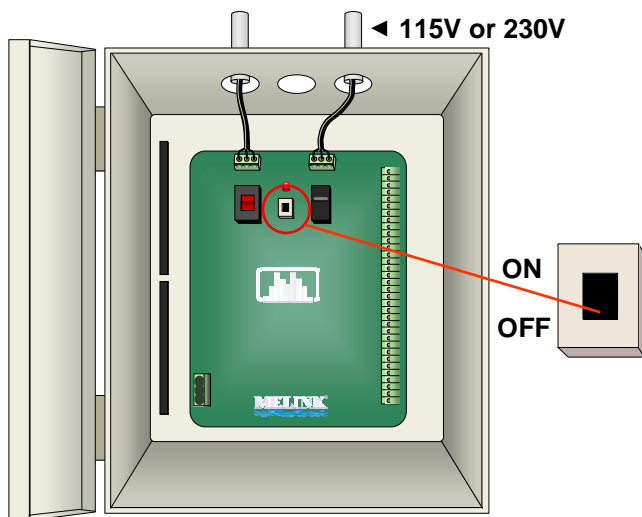

Turn OFF the I/O Processor power switch before wiring. Also turn off the breaker feeding this circuit.

C

Wire I/O Processor

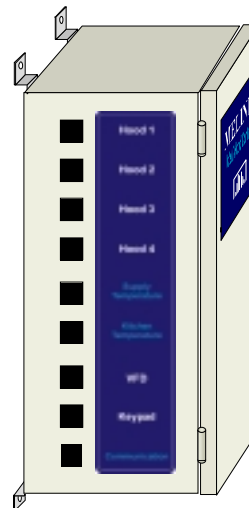

For both New Construction & Retrofits, wire the I/O Processor using the hood light circuit. The circuit must be either 115V or 230V, at 50-60Hz.

D

Wire Connections Inside I/O Processor

Retrofits:
You do not need to use these output terminals if you want to use the existing hood light switch to control the hood lights. Otherwise, wire the same as for new construction.

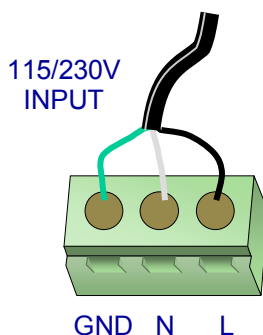

New Construction & Retrofits:
Main Input Power
from Hood Light Circuit
115/230 VAC

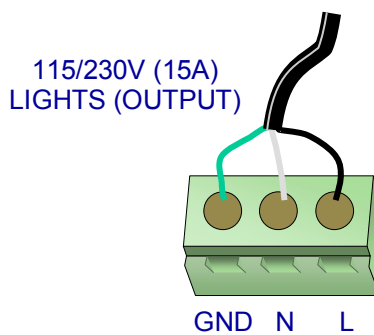

New Construction:
Outgoing Power to Hood Lights
115/230 VAC
15 Amps max



STEP

2

Install Electronic Motor Starter

A

Verify Electronic Motor Starter Wiring

For new construction, the Intelli-Hood includes an Electronic Motor Starter (also referred to as Variable Frequency Drive or VFD) for each kitchen exhaust and make-up air fan. This type of starter is for use with 3-phase motors only. It not only turns the fans on and off, but also varies the speed of the motors by varying the output frequency and voltage. Therefore, you do not need a conventional magnetic motor starter with our system. **Caution:** If you have a tempered make-up air unit, then the control circuit for the heating system must be fed by a separate power source and NOT from the Electronic Motor Starter! The output of the Electronic Motor Starter must be wired to the motor ONLY and NOT to a transformer or any part of a control circuit!

If there is a make-up air unit, then the Electronic Motor Starter for this unit must be interlocked with the fire suppression micro-switch so that this fan turns off in the event of a fire. This is accomplished by connecting a low-voltage cable between designated terminals on the Electronic Motor Starter (01 and 04 for Allen-Bradley) and the Normally Closed (NC) terminals on the micro-switch. **Caution:** With variable frequency drives, there must be a separate conduit run for the output of each VFD (inputs may be run together if desired). If this is not done, there is a strong probability of problems due to line interference and inaccurate motor control.

For retrofits, the only difference between new construction and retrofits is that on retrofits you will already have conventional magnetic motor starters installed. In most cases, it is recommended that you install the Electronic Motor Starters on the output side of the existing starters. This will enable the cooks/chefs to use the existing hood fan (and light) switch and not have to change their habits. This will also allow you to keep the existing circuit intact between the magnetic starter for the make-up air unit and the fire suppression system micro-switch.



All wiring must comply with the National Electric Code (NEC and local code requirements.



STEP

2

Install Electronic Motor Starter

B

Select VFD Location

For retrofits, each VFD is typically mounted on the output side of the existing motor starter, which is often located in an electrical room, above the hoods, or inside a utility cabinet. For new construction, the hood manufacturer typically provides a utility cabinet in which to mount the VFDs.

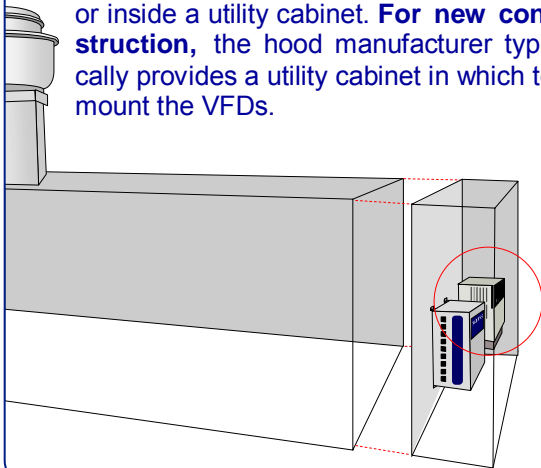

C

Check VFD Location

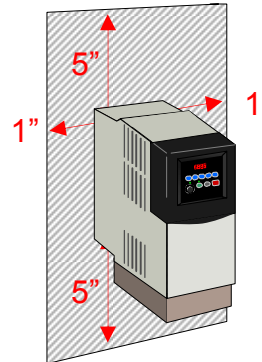

The location must be relatively free of dirt, grease, and water. The ambient temperature must be between +14 degrees F and +122 degrees F. There should be 5" of clearance on the top and bottom and 1" on the sides for adequate ventilation/cooling.

D

Mount VFD

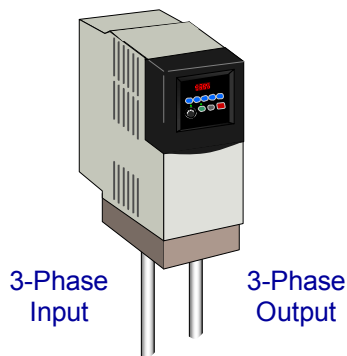

Mount each VFD with appropriate fasteners.

Then install separate conduit for the input and output power wiring to prevent electrical interference between the conductors.

E

Wire VFD

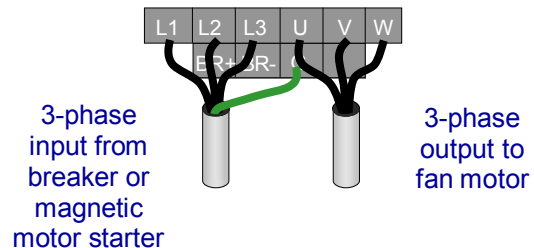

Remove the VFD top cover and connect the line voltage wiring to the VFD input power terminal block as shown above. Then connect the output power from the terminal block to the respective fan motor on the roof. The ground wire must be a minimum of 14 AWG and as short as possible. **The output wiring for each VFD MUST be in a separate conduit run.**



STEP

3

Install Keypad

A Remove Existing Switches

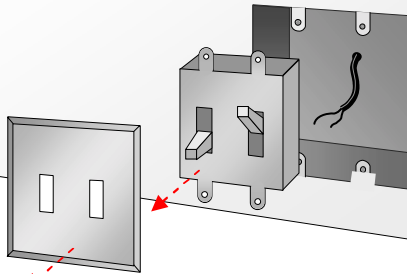

Before removing the switch cover plate, turn off the circuit breaker.

For retrofits, if you want to replace the existing fan and light switch with our Keypad, remove these switches from the junction box. Then remove the existing wires to make room for the Keypad Cable.

B Run Keypad Cable

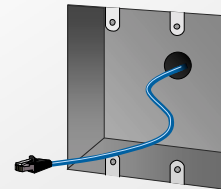

Run the Keypad Cable inside the existing conduit and leave approximately 5 inches of slack inside the junction box. You will connect the other end of the Cable to the I/O Processor in Step 7-D.

C Plug In Cable

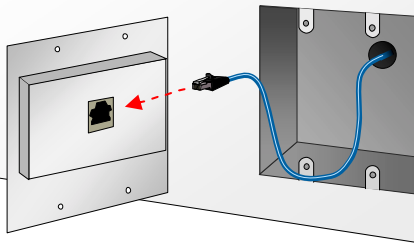

Plug the connector into the receptacle on the back of the Keypad.

D Mount Keypad

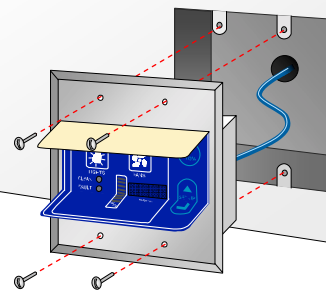

Mount the Keypad to the junction box and secure the cover plate with 4 screws. Peel and stick the top and bottom of the label to cover the screws.

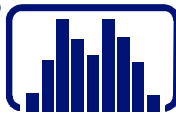

STEP

4

Install Exhaust Temperature Sensor

A

Determine Number of Sensors

Install one (1) Temperature Sensor per exhaust duct, if the length of the duct is less than 24". In most cases this will mean one Temperature Sensor per hood.

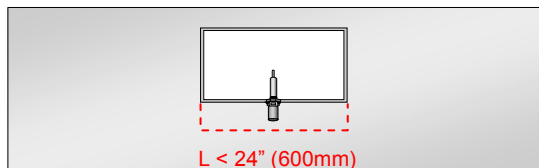

Hood 1 (Top View)

In some cases, this will mean two Temperature Sensors per hood.

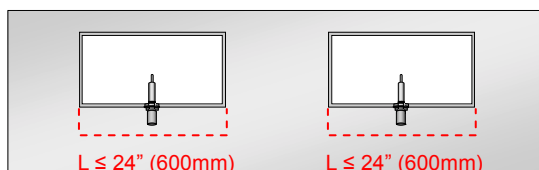

Hood 2 (Top View)

If the length of the duct is more than 24", then install two Temperature Sensors in order to obtain a better average reading.

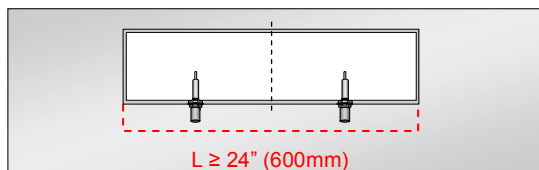

Hood 3 (Top View)

B

Select Location for Mounting Sensor

Select a location for mounting each Temperature Sensor. The tip of the sensor should be inside the center of the duct to sense the average temperature. For most installations, proceed with steps C-F on page 10. An alternate mounting procedure is described in steps C-J on pages 11 and 12.

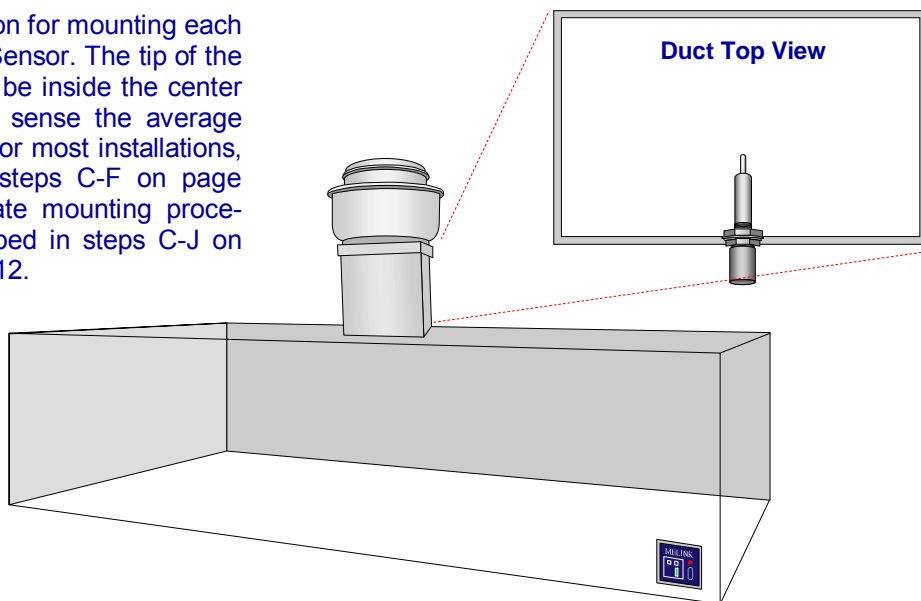

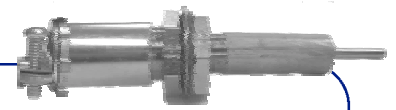
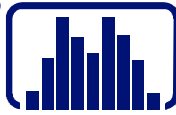

STEP

4

Install Exhaust Temperature Sensor

C

Select Location on Duct

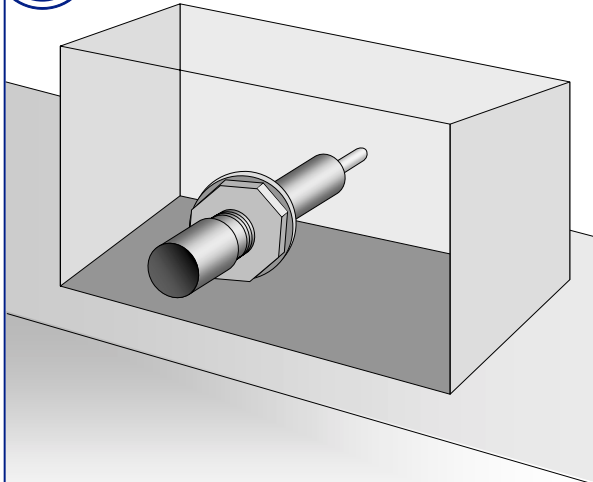

Each Temperature Sensor should be located as closely to the top of the hood as possible for easy access and cleaning.

D

Side View of Sensor

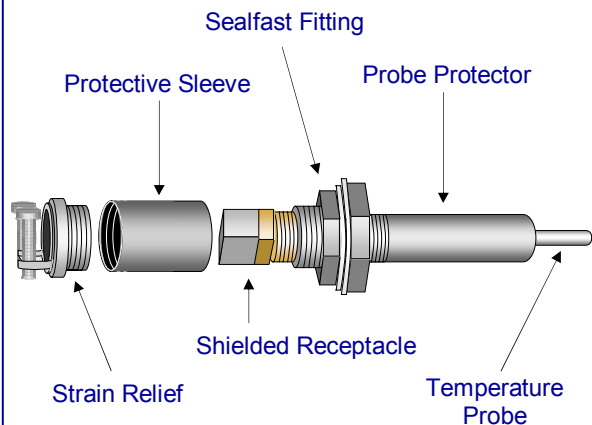

E

Drill Hole in Duct

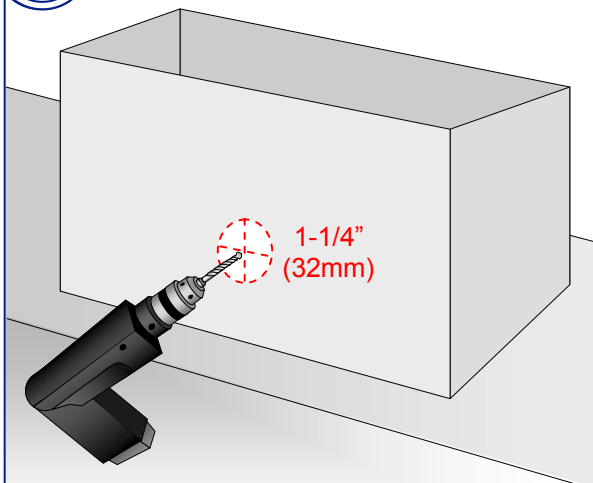

Drill or punch a 1-1/4" (32mm) diameter hole at the proper location for each Temperature Sensor.

F

Mount Sensor

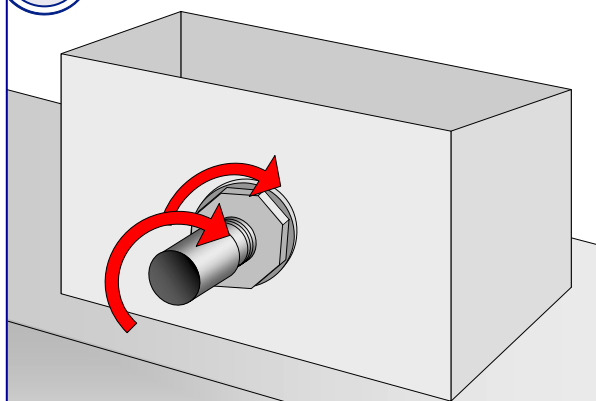

Mount each Temperature Sensor from the inside of the duct. Insert the lock washer and tighten the nut from the outside of the duct, then re-attach protective sleeve and strain relief.

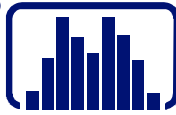

ALTERNATE

4

Install Exhaust Temperature Sensor

C

Select Location on Duct

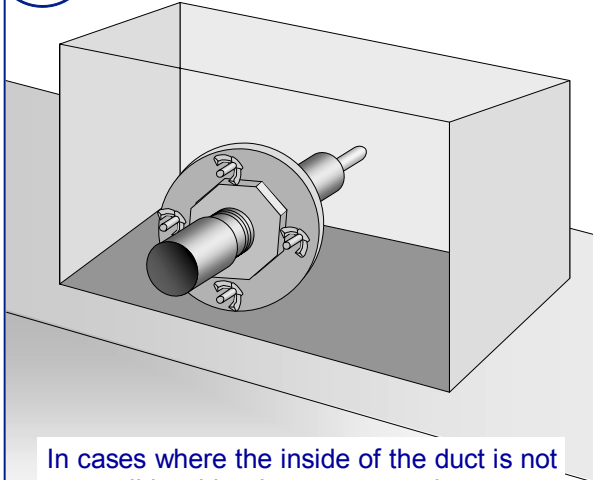

In cases where the inside of the duct is not accessible, this alternate mounting procedure may be used. Begin with steps A-B, then continue with these alternate steps C-J.

D

Side View of Sensor

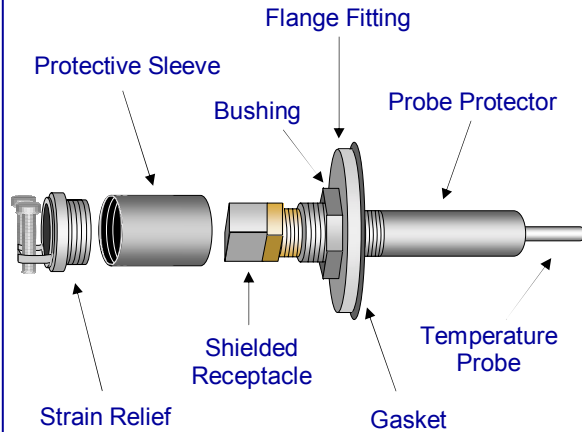

E

Mark Hole Locations

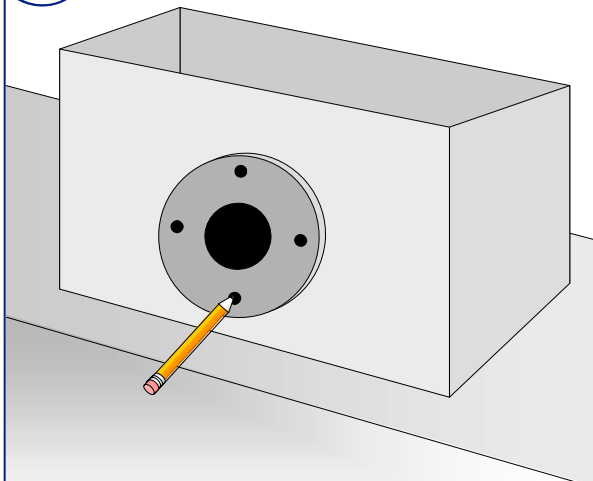

Using the gasket as a template, mark the hole locations for each Temperature Sensor.

F

Drill Hole in Duct

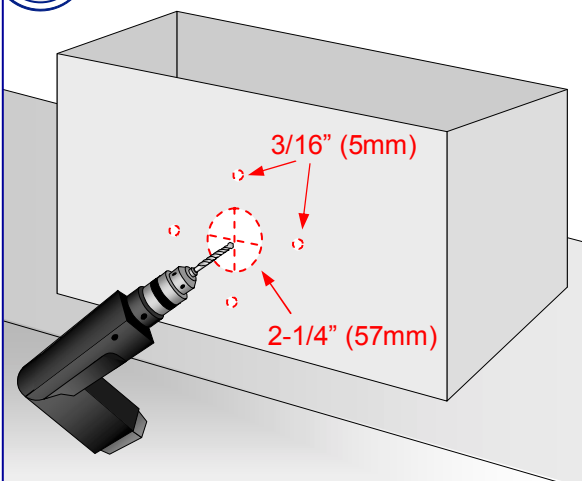

Drill or punch a 2-1/4" (57mm) diameter hole and drill (4) 3/16" holes at the marked locations.

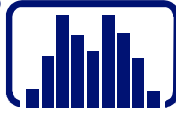

ALTERNATE

4

Install Exhaust Temperature Sensor

G

Insert Studs

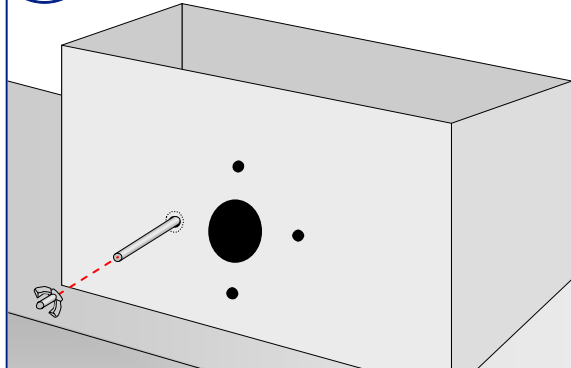

By reaching into the 2-1/4" hole, insert the stud into the 3/16" hole from inside the duct so that the threaded end is protruding outward. Tighten the wing nut onto the stud until its self-clenching base is securely wedged into the hole. Repeat this step for the other studs.

H

Tighten Studs

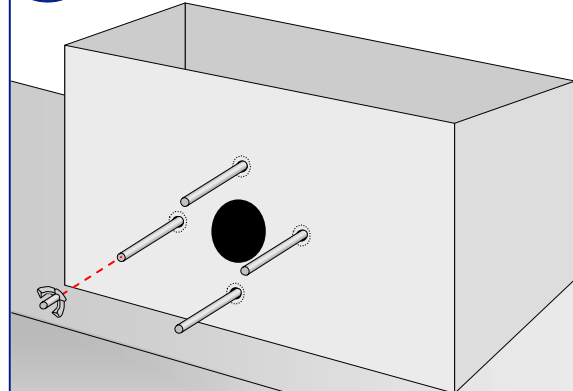

Remove wing nut from each stud. Check to be sure that all the studs are securely wedged into each hold. If any feel loose, re-tighten the wing nut onto the stud using a wrench. Remove all remaining wing nuts.

J

Mount Sensor

Place the gasket over the studs, followed by the flange fitting. Tighten with the (4) wing nuts using an adjustable wrench until the unit is secure. Check around the seal to make sure the flange is sitting flush to the duct with no gaps.

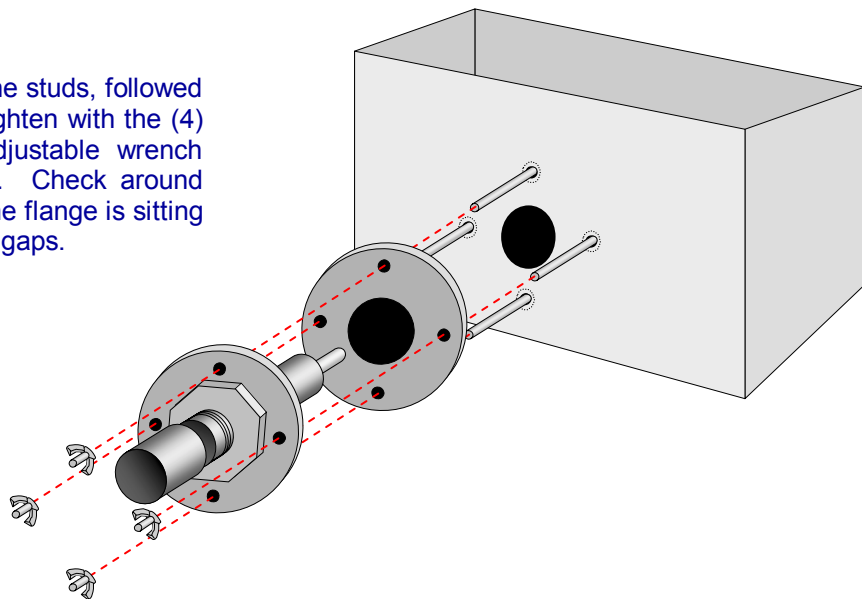

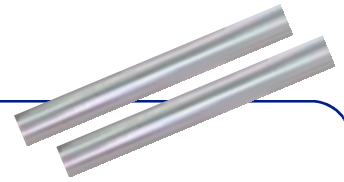
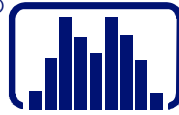

STEP

5

Install Optic Sensors

A

Check Hood

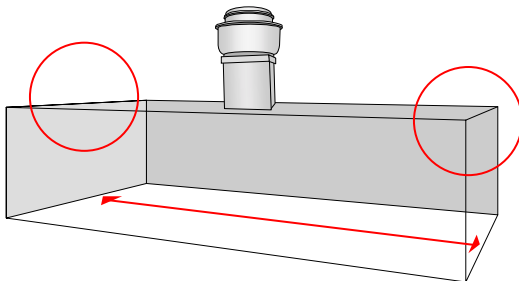

Make sure there are no obstructions at least 10" (254mm) from where you need to penetrate the top of the hood. Also, make sure the location will not cause the Optic Sensor beam to be obstructed by anything, such as fire suppression piping.

B

Select Sensor Locations

Approx. 3" is typical.

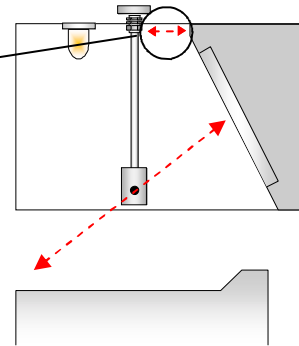

To determine where to install the Optic Sensors, imagine a virtual line between the front

of the cooking surface and the middle of the hood filters. The Optic Sensors should be mounted along that virtual line inside the ends of the hood. (This is typically about 3" from where the filter bank meets the top of the hood.) Also, the Optic Sensors must be mounted directly across from each other.

C

Mark Hole Locations

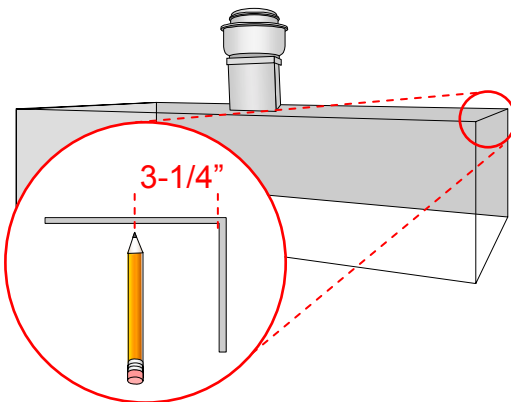

The hole locations need to be centered 3-1/4" (83 mm) from the **inside** ends of the hood. Drill a small pilot hole to mark these exact locations.

D

Drill Holes in Hood

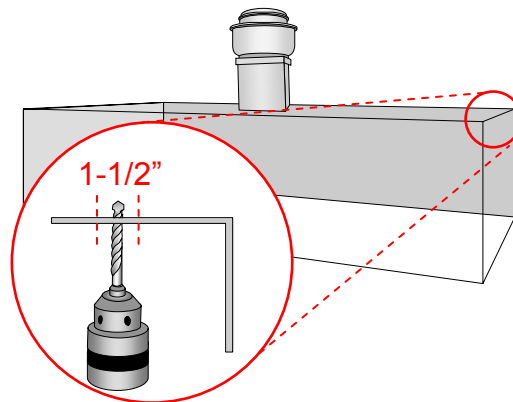

Then drill or punch a 1-1/2" (38mm) hole at these same locations.

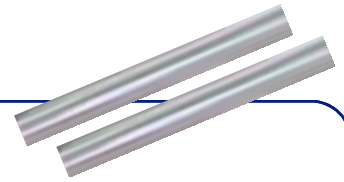
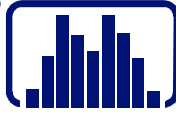

STEP

5

Install Optic Sensors

E

Install Fittings

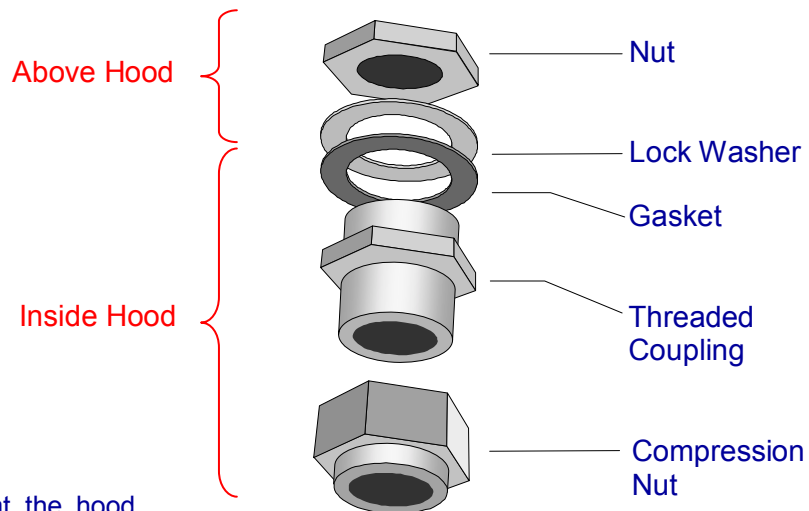

Install the Fittings at the hood penetrations in the order shown.

F

Install Purge Pipes

Insert the Purge Pipes inside the Fittings with the notch positioned above the hood. Tighten the Fitting temporarily, until the Optic Sensors are mounted.

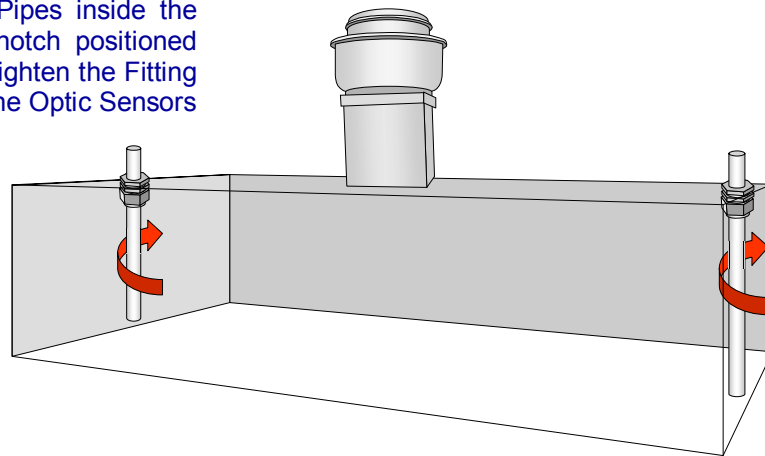

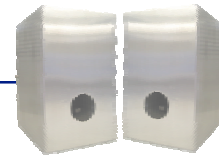

STEP

5

Install Optic Sensors (Optic Enclosures)

G Disengage Optic Sensors

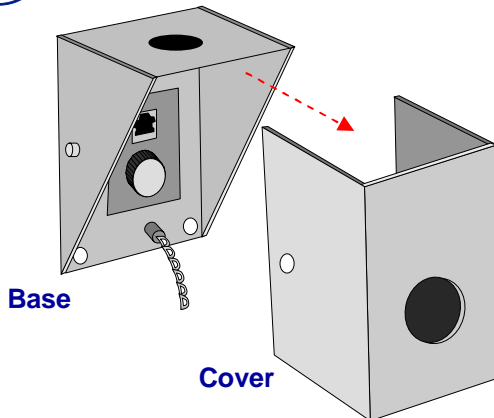

Disengage the cover from the base on each Optic Sensor. One has a circuit board labeled 'Emitter', and the other is labeled 'Receiver'. **The 'Receiver' should be mounted closest to the I/O Processor.**

H Mark Hole Locations

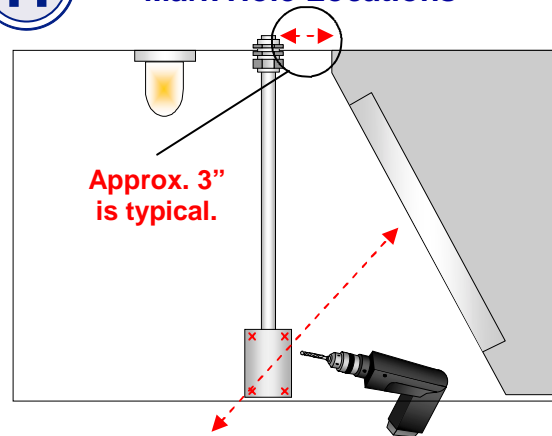

Use the base of each Optic Sensor as a template to mark the location for two mounting holes. Be sure to locate the Optic Sensor in the virtual line mentioned in step 5-B. Drill 3/16" holes.

J Mount Optic Sensor Base

Mount the base with two stainless steel screws. The screws can be located inside or outside of the hood, depending upon the location of the hood. If the hood is located against a wall, then self-tapping screws from the inside must be used. If the hood is not located against a wall, then use the machine screws, washers and nuts provided.

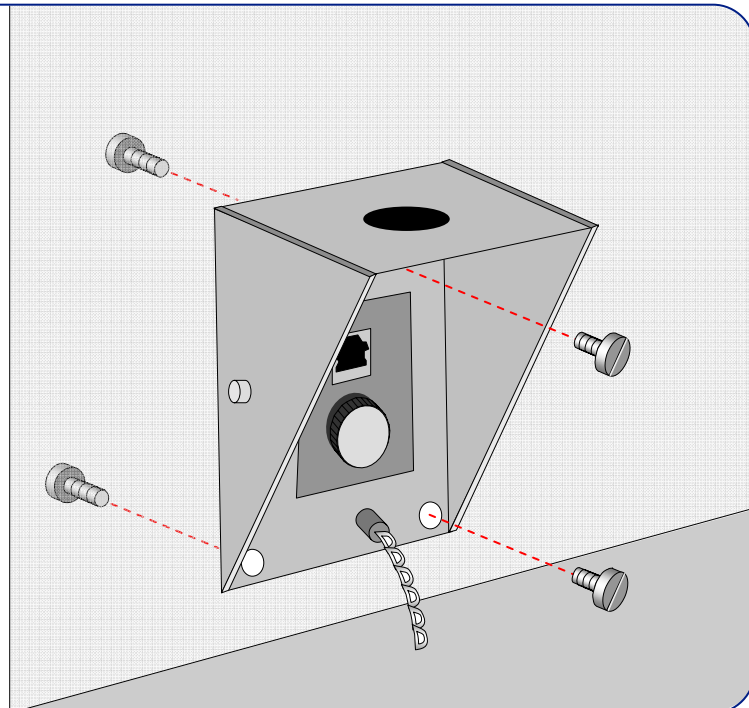

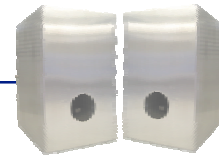

STEP

5

Install Optic Sensors

K

Install Optic Cables

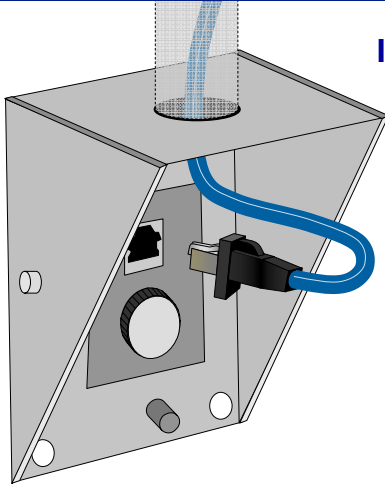

Emitter

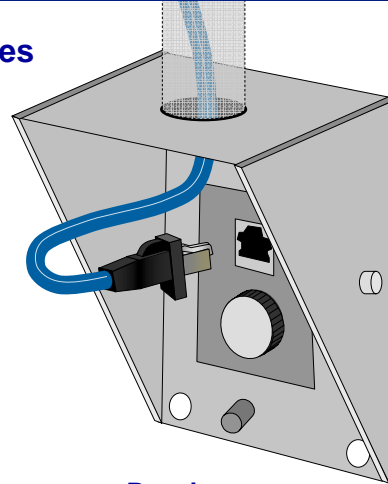

Receiver

Remove the Optic Cables from the box. Insert the end of one cable with the small anti-sag boot up through the purge pipe from the optic housing with the Emitter Board. Plug in the cable end with the large anti-sag boot into the jack on the Emitter Board and push any excess slack up the purge pipe. Mount the cover onto the base. Repeat with Receiver Board.

L

Run Cable Up Purge Pipes

Run the cables up each Purge Pipe and verify that they are located inside the notches before installing the APUs.

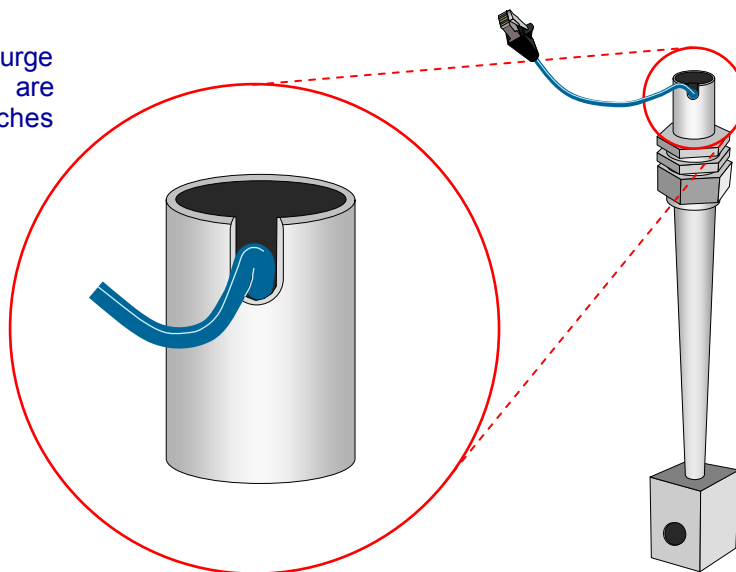

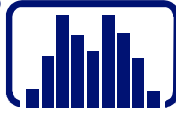

STEP

6

Install Air Purge Units

A

Attach APU to Purge Pipe

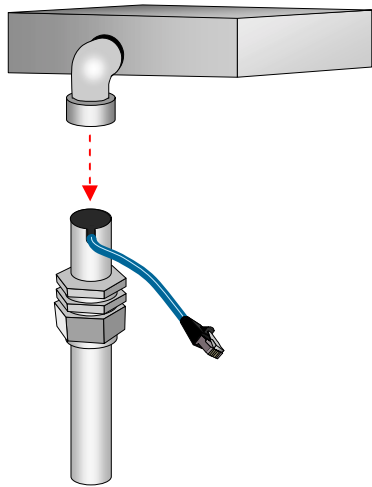

Attach an APU to each Purge Pipe and tighten the compression fitting.

B

Remove APU lids

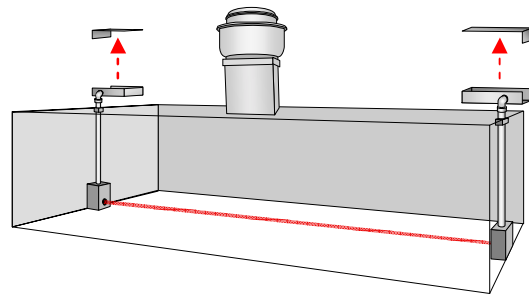

Remove the lids from each APU box to prepare for step 7.

C

Plug In Optic Cables

Plug the Optic Cables into any receptacle on the header board inside each APU. Then run a cable from APU box to APU box.

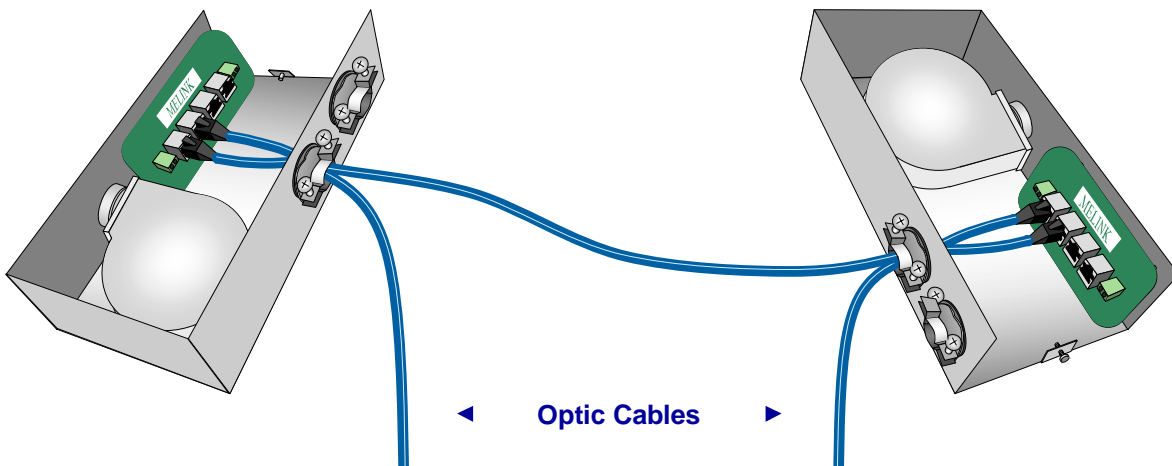

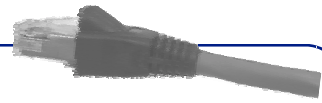
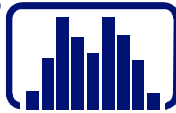

STEP

7

Install Cables (Electronic Motor Starter)

A

Plug Cable Into VFD

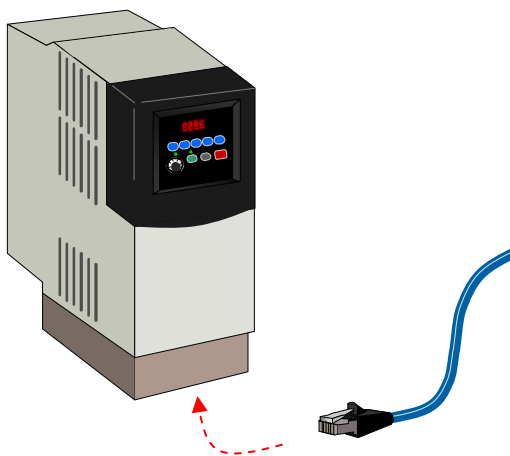

Remove a cable from its package and plug one end into the receptacle on the bottom of one VFD.

B

Plug Into I/O Processor

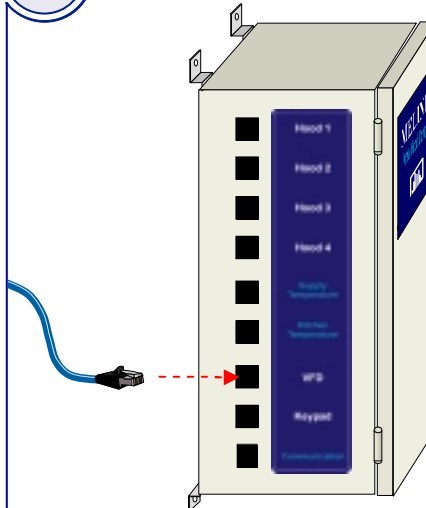

Then plug the other end of the cable into the receptacle marked 'VFD' on the side of the I/O Processor.

C

Connect VFDs

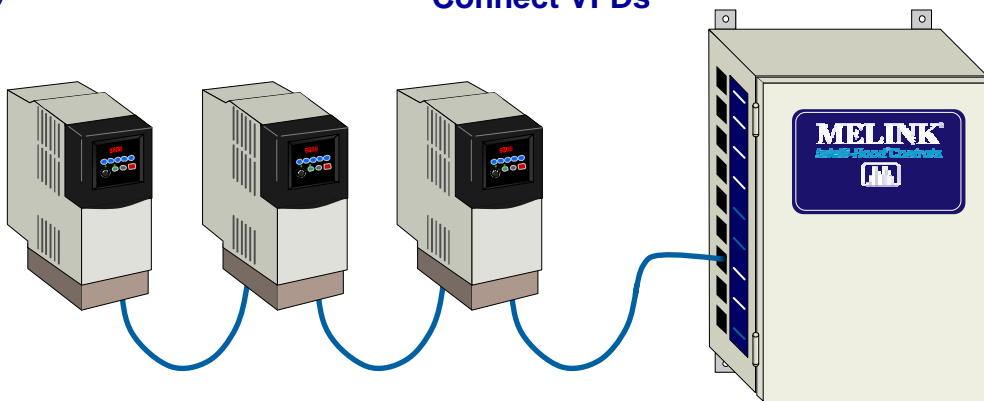

If you have multiple VFDs, plug the remaining VFDs to one another with additional cables, keeping only one VFD plugged to the I/O Processor.

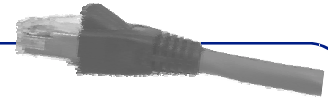
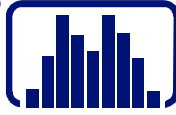

STEP

7

Install Cables (Keypad)

D

Find Keypad Cable

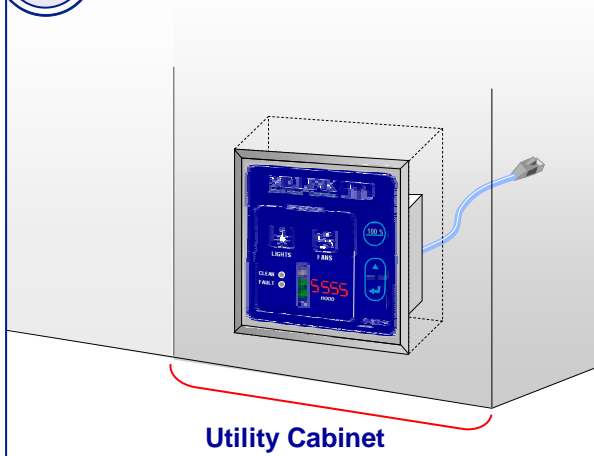

Utility Cabinet

Inside the Utility Cabinet, take the Keypad Cable already connected on one end ...

E

Plug Into I/O Processor

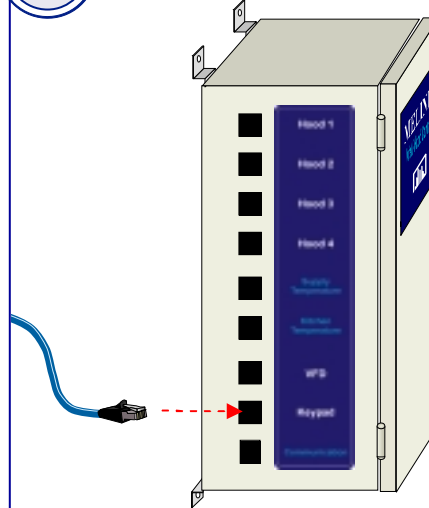

...and run it to the I/O Processor on the other side of the cabinet.

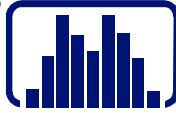

STEP

7

Install Cables (Temperature Sensor)

F

Plug Cable into Temperature Sensor

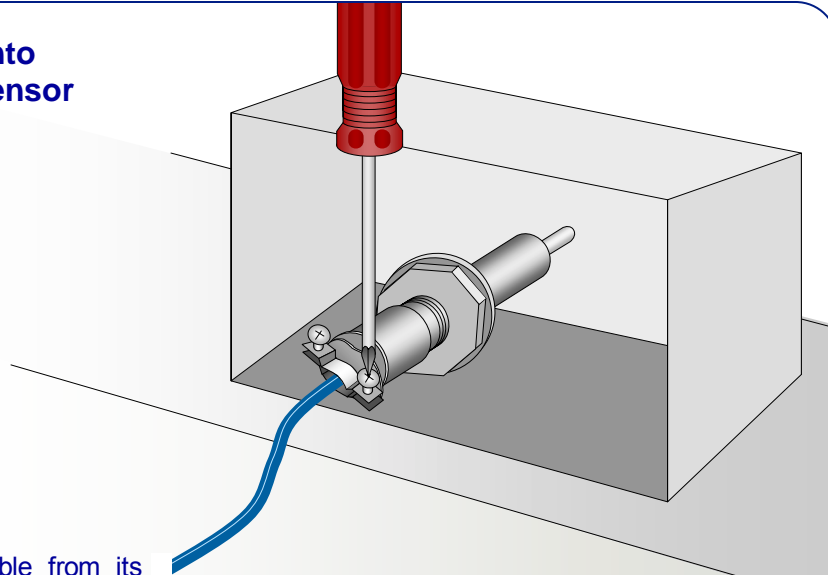

Remove the Temperature Cable from its package. Connect one end to the Temperature Sensor receptacle, and then tighten the strain relief.

G

Plug Into I/O Processor OR APU

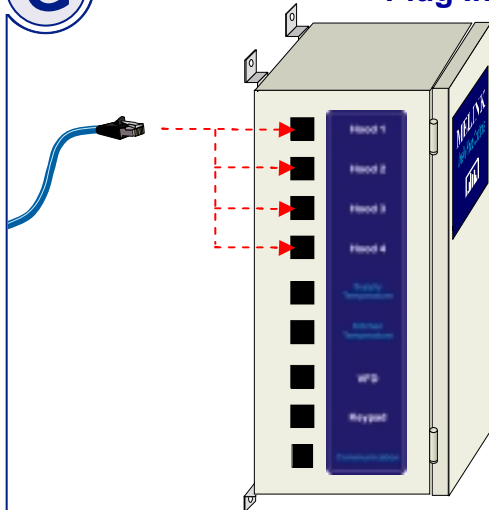

If there are NO Optic Sensors, connect the other end of the cable to the receptacle for the respective hood on the I/O Processor.

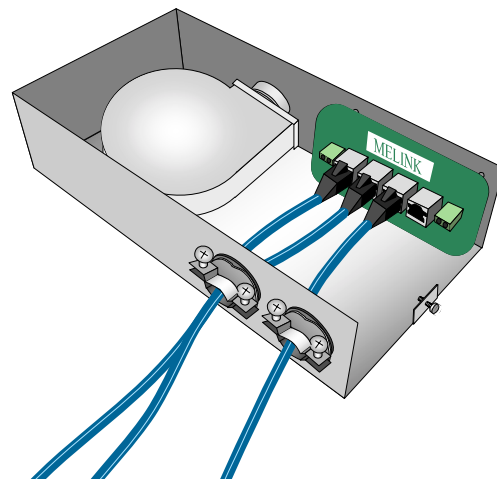

If there ARE Optic Sensors, connect the other end to any receptacle in the APU box. Repeat as necessary for each hood.



STEP

7

Install Cables (Temperature Sensor)

H

Connect Multiple Sensors (if applicable)

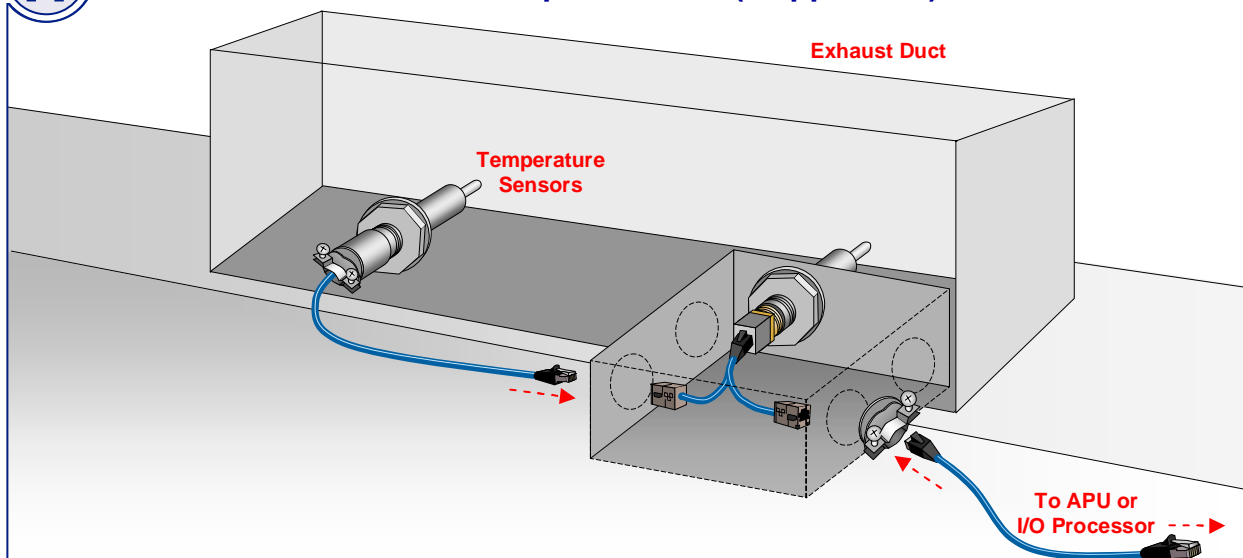

If you need more than one Temperature Sensor for any hood, connect them in series with a "Y" Connector as shown. Then run the other end of the cable to the Air Purge Unit (or to the I/O Processor if there are no Optic Sensors).

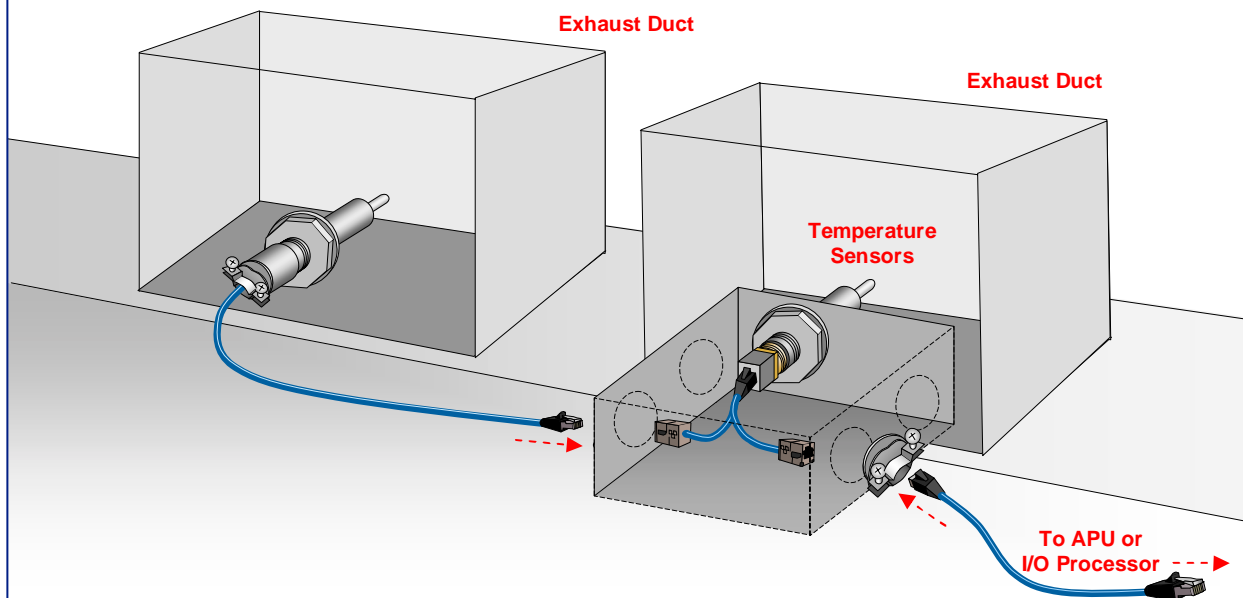

For multiple exhaust ducts, connect the Temperature Sensors in the same way.

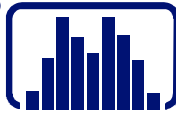

STEP

7

Install Cables (Optic Sensors)

J

Plug Cable Into Processor

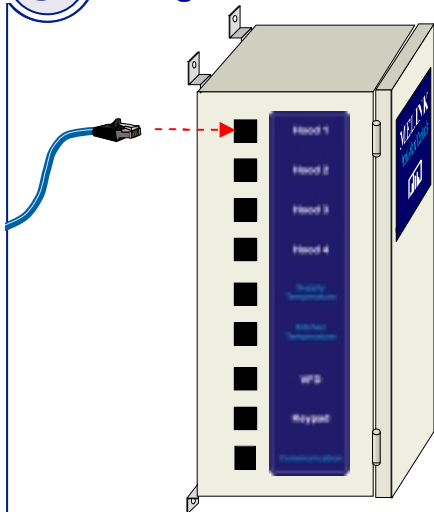

Remove a cable from its package and plug one connector into the first receptacle ('Hood 1') of the I/O Processor as shown.

K

Plug Into APU

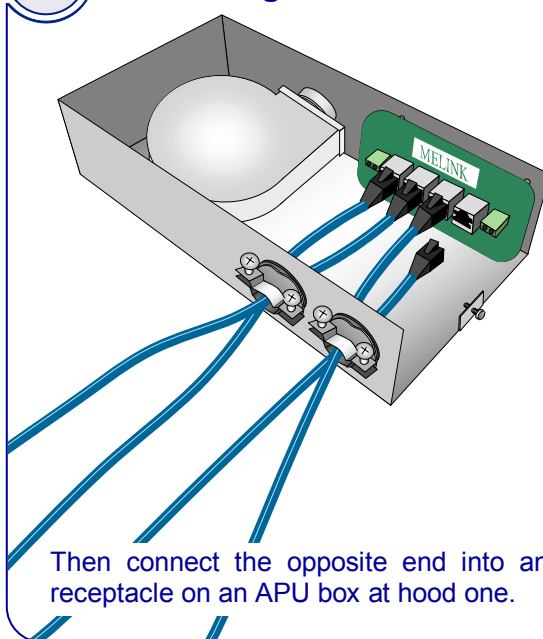

Then connect the opposite end into any receptacle on an APU box at hood one.

L

Tighten Strain Reliefs

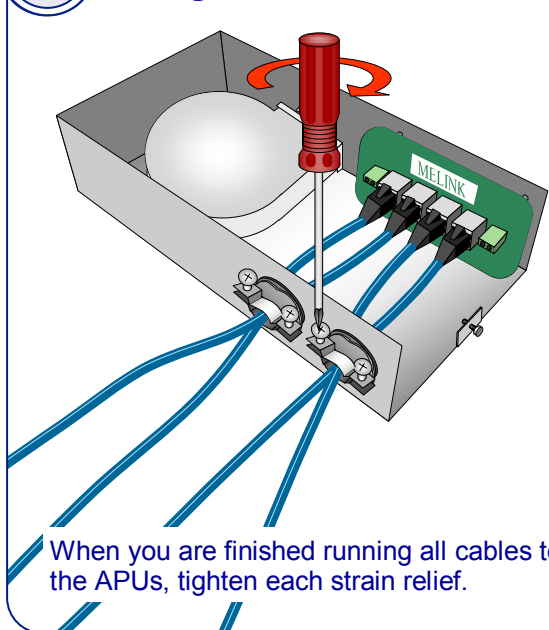

When you are finished running all cables to the APUs, tighten each strain relief.

M

Secure APU Lid

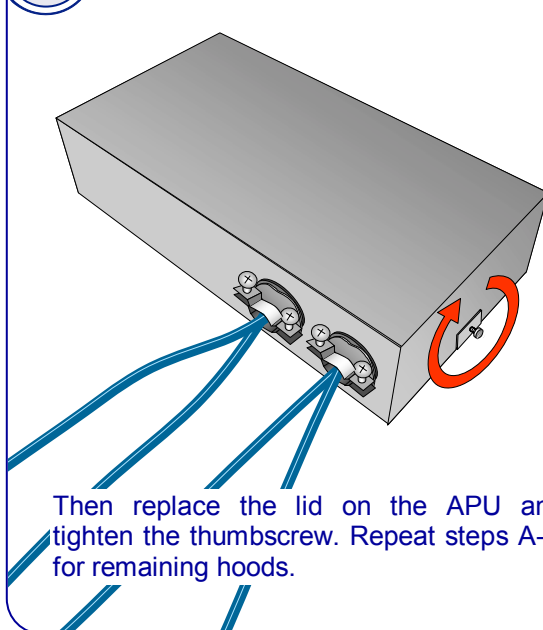

Then replace the lid on the APU and tighten the thumbscrew. Repeat steps A-D for remaining hoods.

OPTION

1

Fire Suppression Switch

A

Connect Fire Suppression Switch to VFD

If you installed an Electronic Motor Starter for a make-up air or supply fan, then you will need to make sure it is interlocked with the fire suppression system. The purpose is to make sure that this fan shuts down in the event of a fire. This is accomplished by running the VFD on/off control signal to the fire suppression micro-switch. If/when this normally closed (N.C.) switch opens, the VFD shuts down power to the fan.

Connect your Ansul micro-switch to terminals 01 and 04 of the VFD.

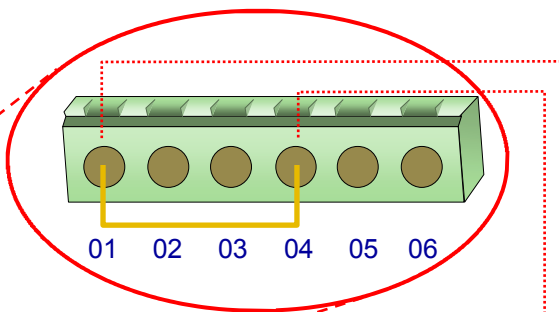
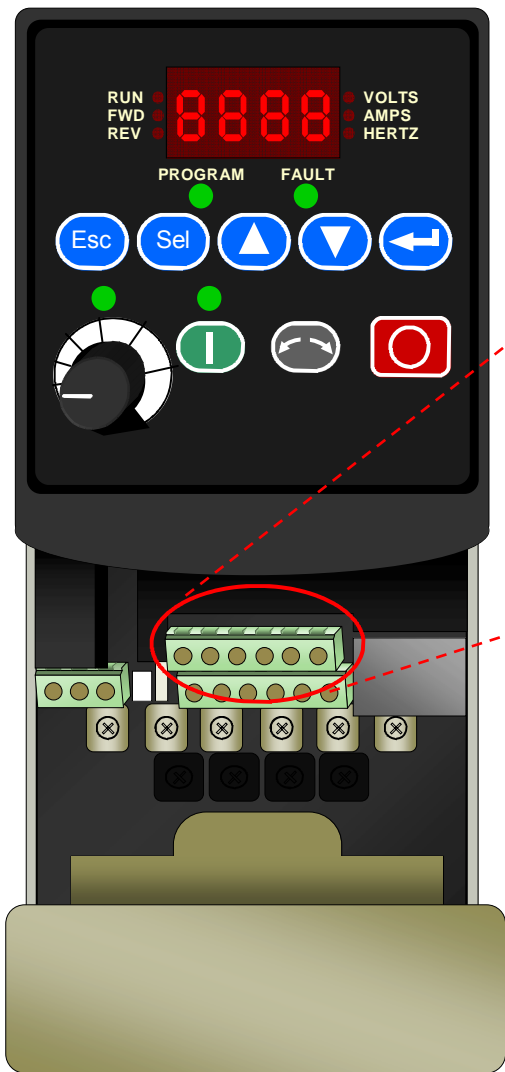

Note: The fire suppression micro switch (N.C.) is not provided by Melink.

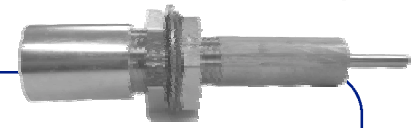

OPTION

2

Install Supply Temperature Sensor

A Install Temperature Sensor

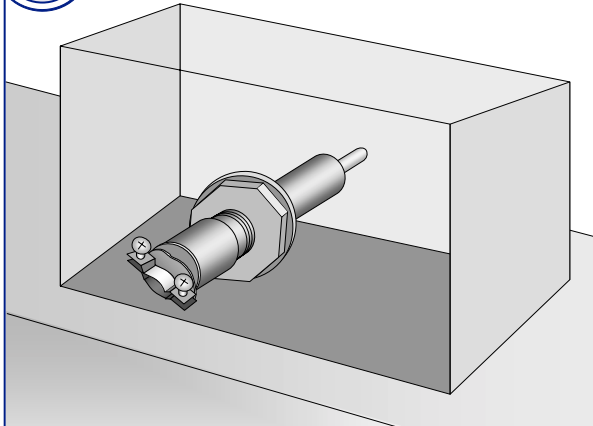

Install the Supply Temperature Sensor in the make-up air duct using one of the two mounting procedures shown in Step 4.
Note: You only need to install one Supply Temperature Sensor in any given store.

B Plug Cable Into I/O Processor

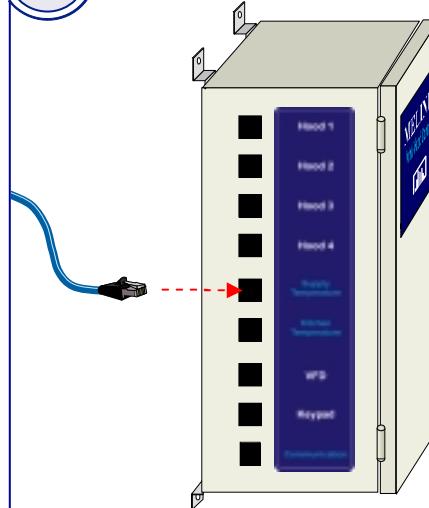

Plug a cable into the Supply Temperature receptacle of the I/O Processor.

C Plug Cable Into Temperature Sensor

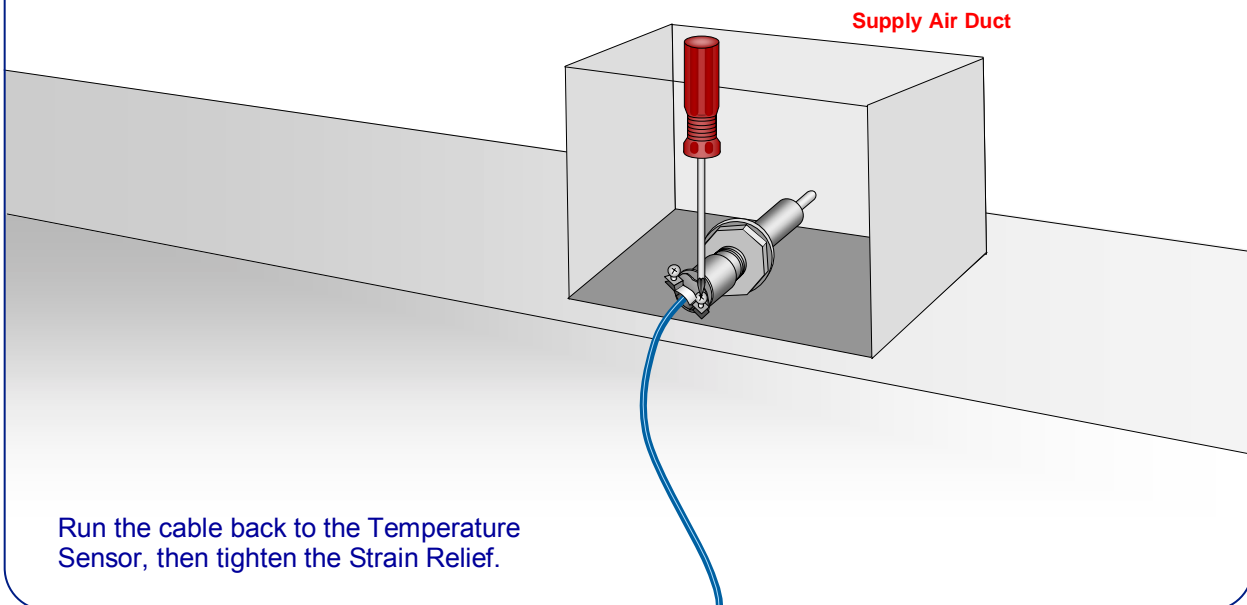

Run the cable back to the Temperature Sensor, then tighten the Strain Relief.



OPTION

3

Install Kitchen Temperature Sensor

A

Select Suitable Location

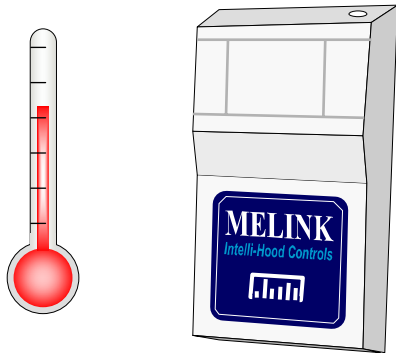

The Kitchen Temperature Sensor must be located away from any hot or cold spots. (such as above a kitchen appliance or underneath a ceiling diffuser). Choose a location that best represents the average temperature of the kitchen.

B

Attach Base to Wall

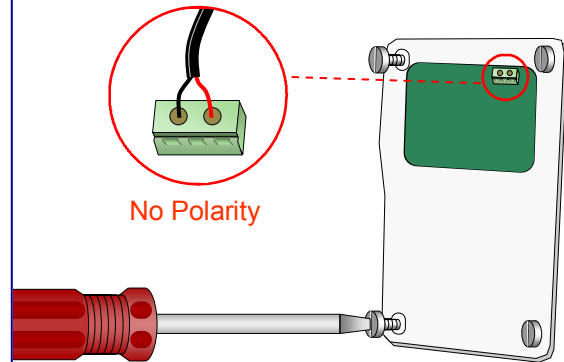

Detach the base from the cover and secure it to the selected location on the wall. Connect one end of the cable to the terminal block on the base.

C

Connect Cable to I/O Processor

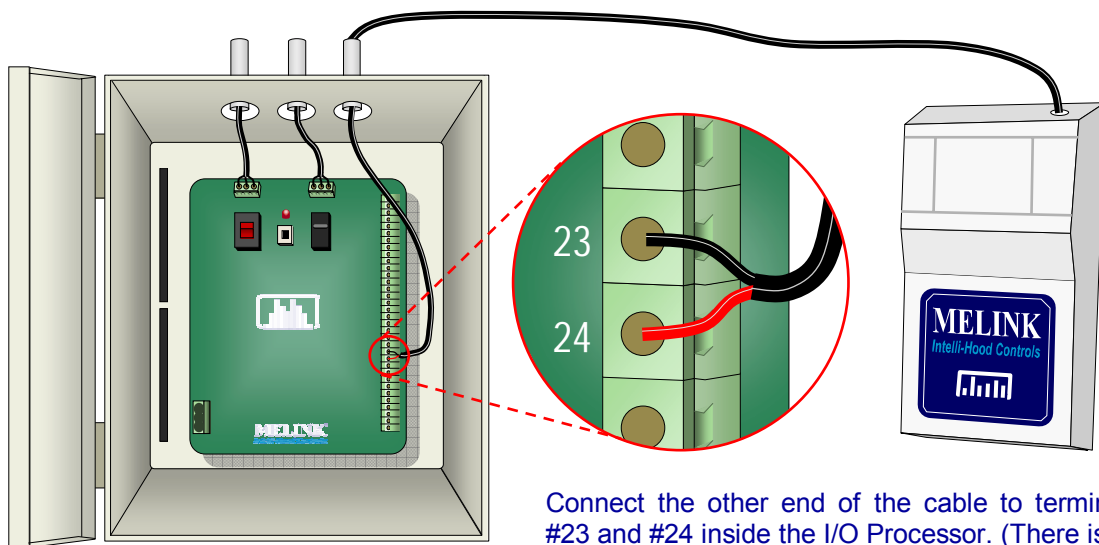

Connect the other end of the cable to terminals #23 and #24 inside the I/O Processor. (There is no polarity for this connection.)



OPTION

4

Install Optional Sensors (Humidity or CO₂)

A

Install Humidity or CO₂ Sensors

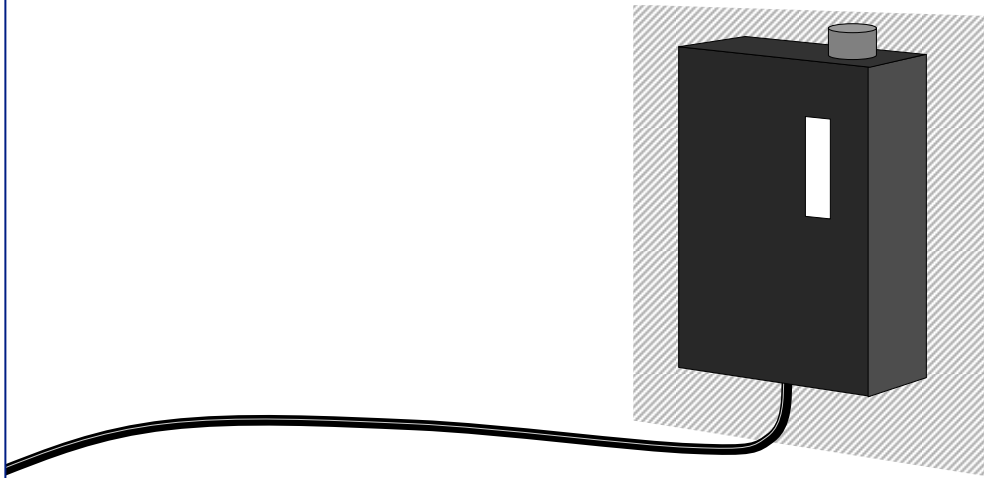

Remove the sensor from its package and install in accordance with the manufacturer's instructions.

B

Connect Cable to I/O Processor

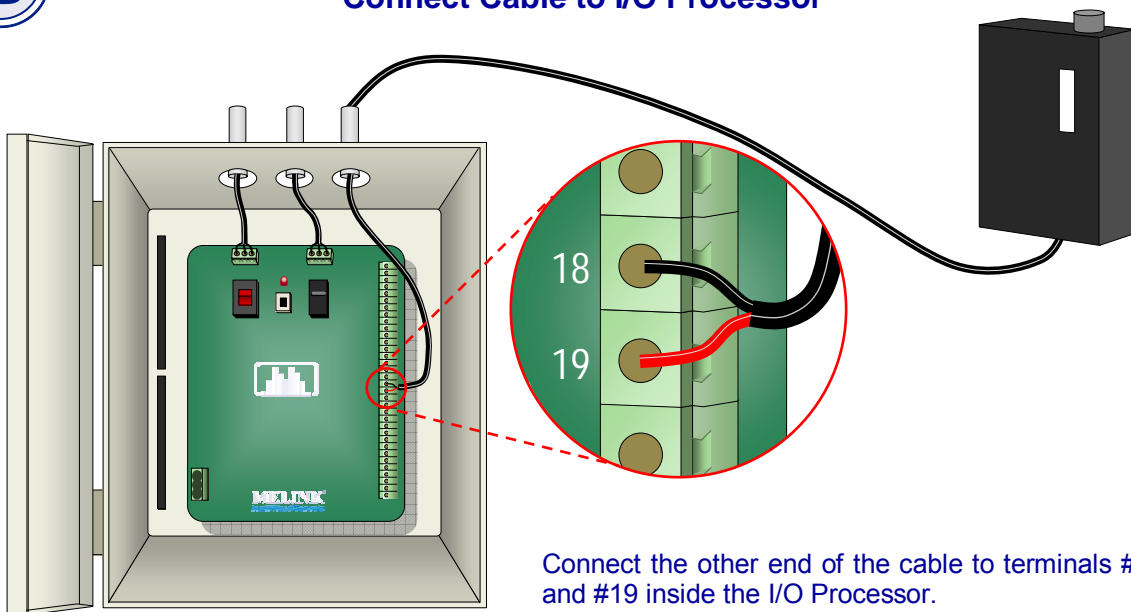

Connect the other end of the cable to terminals #18 and #19 inside the I/O Processor.

Call Melink Customer Service at (513) 965-7300 if you have any questions.

Please let us know how we can improve our Installation Manual.
We want your experience with our product to exceed all expectations.

